

THIS DRAWING IS UNPUBLISHED. RELEASED FOR PUBLICATION
 © COPYRIGHT - By - ALL RIGHTS RESERVED.

LOC		DIST		REVISIONS			
P	LTR	DESCRIPTION		DATE	DWN	APVD	
	L	REV PER ECO 13-016525		12-9-13	CT	JW	

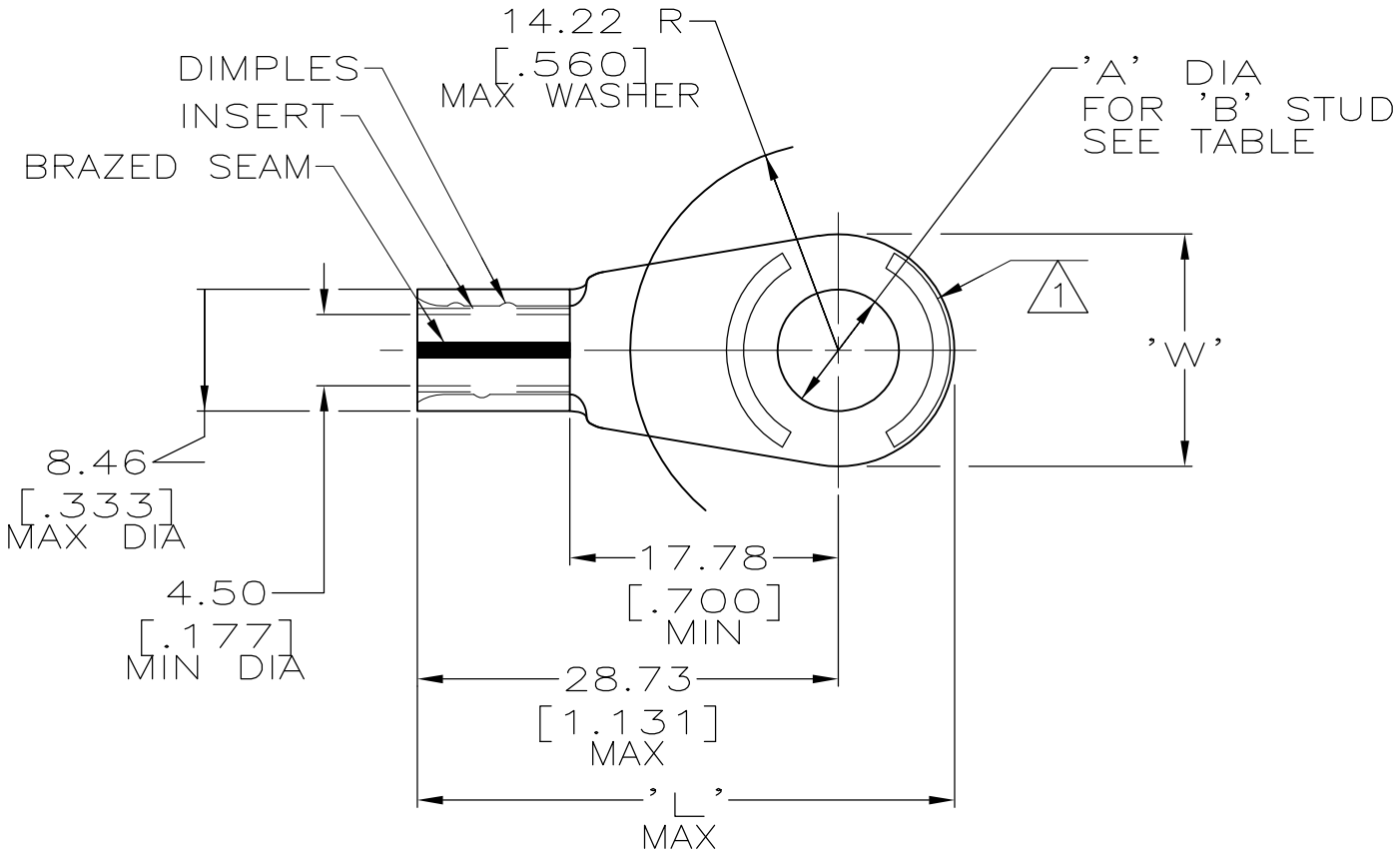

- 1 STAMP 8 AL90CU APPROX AS SHOWN
- 2 MATERIAL THK: 1.14 ±0.08 [.045 ±.003]

OBSOLETE	-3.68±0.08 [.145±.003]	#6	35.15 [1.384]	12.70 [.500]	BODY: COPPER PER ASTM B-152 TIN PL 0.00254[.000100] MIN THK PER MIL-T-10727 INSERT: BRASS PER MIL-C-50 TIN PL 0.00254[.000100] MIN THK PER MIL-T-10727	50720-5
OBSOLETE	-11.51±0.13 [.453±.005]	7/16	15.88 [.625]	36.73 [1.446]		50720-4
OBSOLETE	-9.91±0.13 [.390±.005]	3/8	15.88 [.625]	36.73 [1.446]		50720-3
	8.33±0.13 [.328±.005]	5/16	15.88 [.625]	36.73 [1.446]		50720-2
	6.73±0.13 [.265±.005]	1/4	35.15 [1.384]	12.70 [.500]		50720-1
	5.00±0.08 [.197±.003]	#10	35.15 [1.384]	12.70 [.500]		50720
	'A'	'B'	'L'	'W'		MATERIAL & FINISH

**AMP INCORPORATED
CUSTOMER SERVICE SYSTEMS**

FOR ADDITIONAL PRODUCT INFORMATION OR COPIES OF DRAWINGS AND TECHNICAL DOCUMENTS	PRODUCT INFORMATION CENTER 1-800-522-6752	RECOMMENDED OPERATING TEMPERATURE: 150° C MAX
FOR APPLICATION TOOLING INFORMATION	TOOLING ASSISTANCE CENTER 1-800-722-1111	VOLTAGE RATING: NOT APPLICABLE
FOR ORDER ENTRY	1-800-526-5142	WIRE CROSS SECTIONAL AREA RANGE: 6.64-10.53mm ² [13,100-20,800] CIR MILS STRANDED

THIS DRAWING IS A CONTROLLED DOCUMENT.

DIMENSIONS: mm	TOLERANCES UNLESS OTHERWISE SPECIFIED:
	0 PLC ± - 1 PLC ± - 2 PLC ± 0.20[.008] 3 PLC ± - 4 PLC ± - ANGLES ± -
MATERIAL SEE TABLE	FINISH SEE TABLE

DWN DK SCHRUM 09SEP96	TE Connectivity	NAME	
CHK DM SWARTZ 11SEP96		TERMINAL ASSEMBLY, RING TONGUE, STRANDED/SOLID, COPALUM TM	
APVD JL MECKLEY 11SEP96		SIZE	CAGE CODE
PRODUCT SPEC	A300779		C-50720
APPLICATION SPEC	RESTRICTED TO	-	
WEIGHT	CUSTOMER DRAWING		SCALE 2:1
	SHEET	1 OF 1	REV L